

- I** Posti esterni serie Agorà
- GB** Agorà external door stations
- F** Plaques de rue série Agorà
- E** Placas de calle serie Agorà
- P** Postos externos série Agorà
- D** Türstationen Séries Agorà

Mi 2415

FARFISA

AG100V
AGL100V

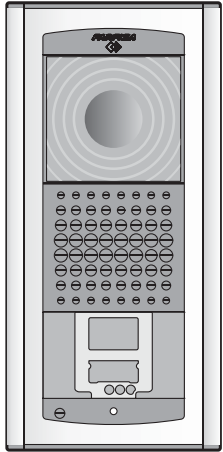

AG100A
AGL100A

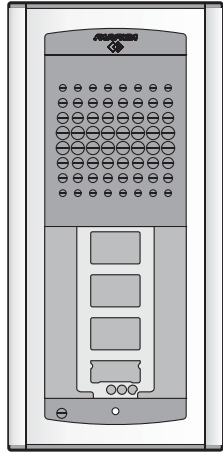

AG100T
AGL100T

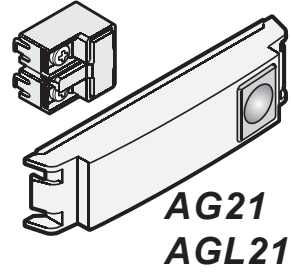
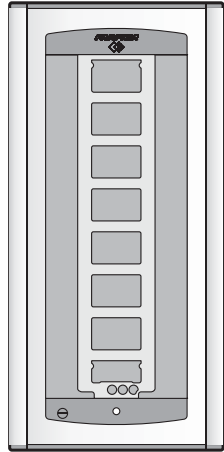

AG21
AGL21

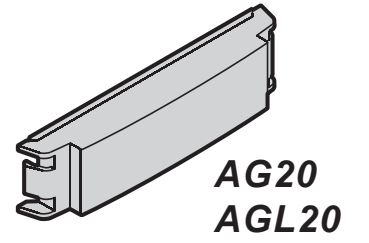

AG20
AGL20

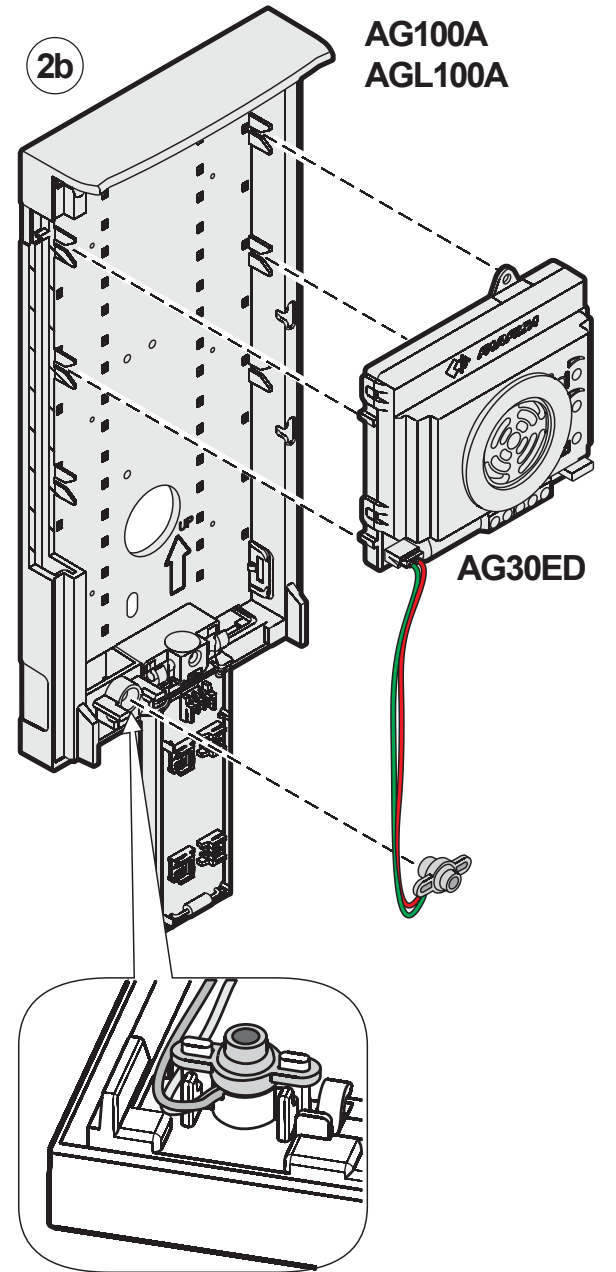
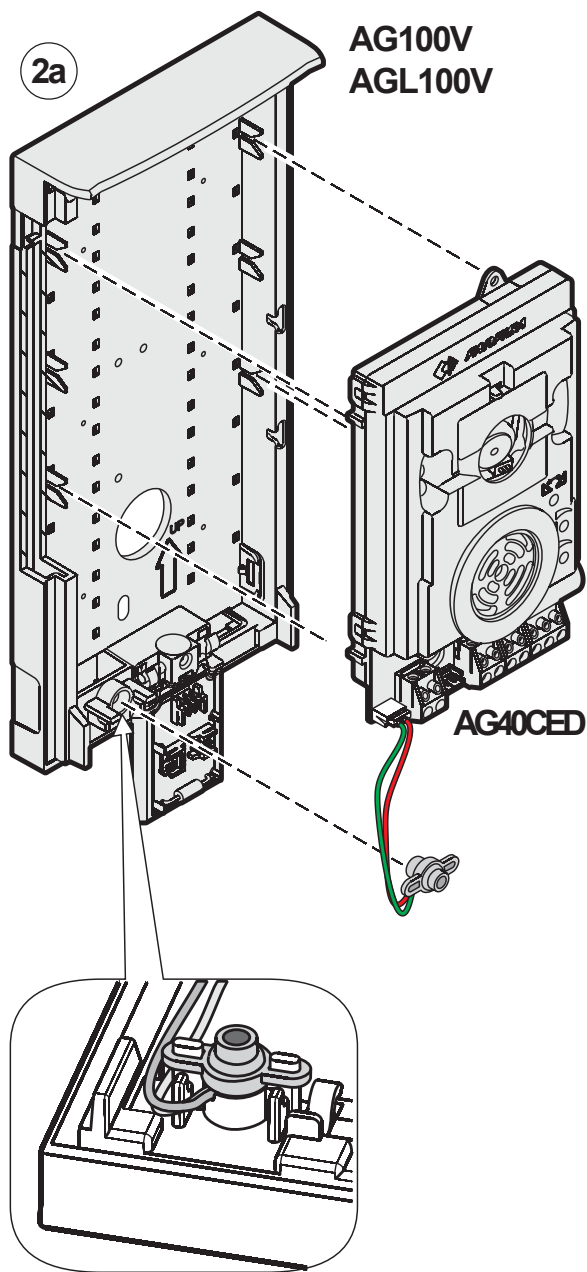
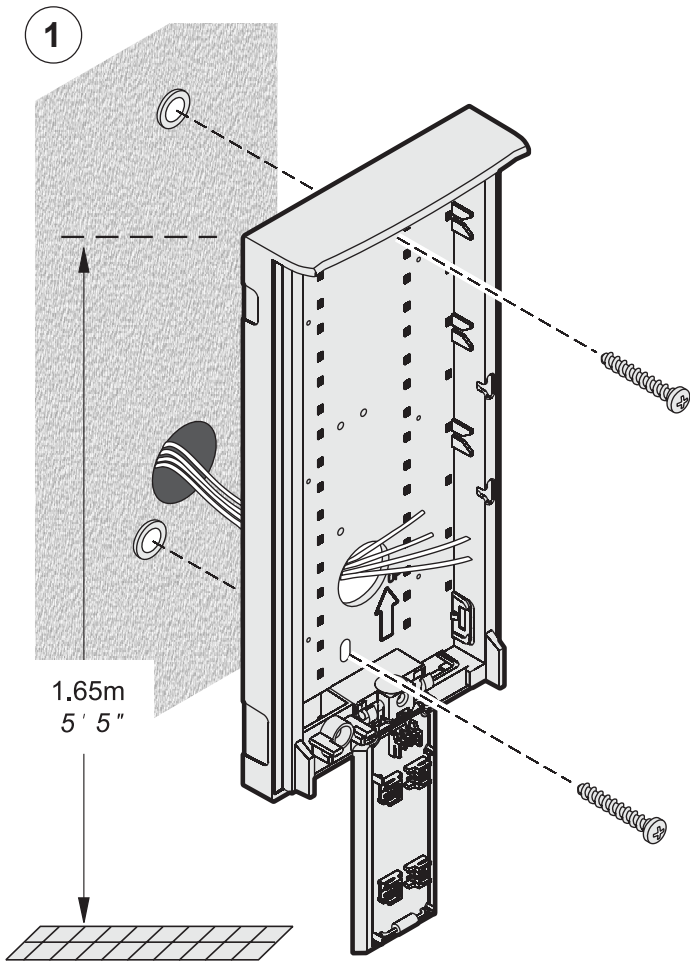
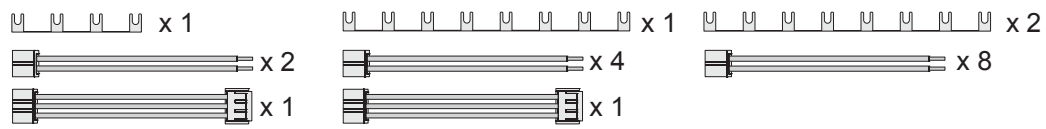

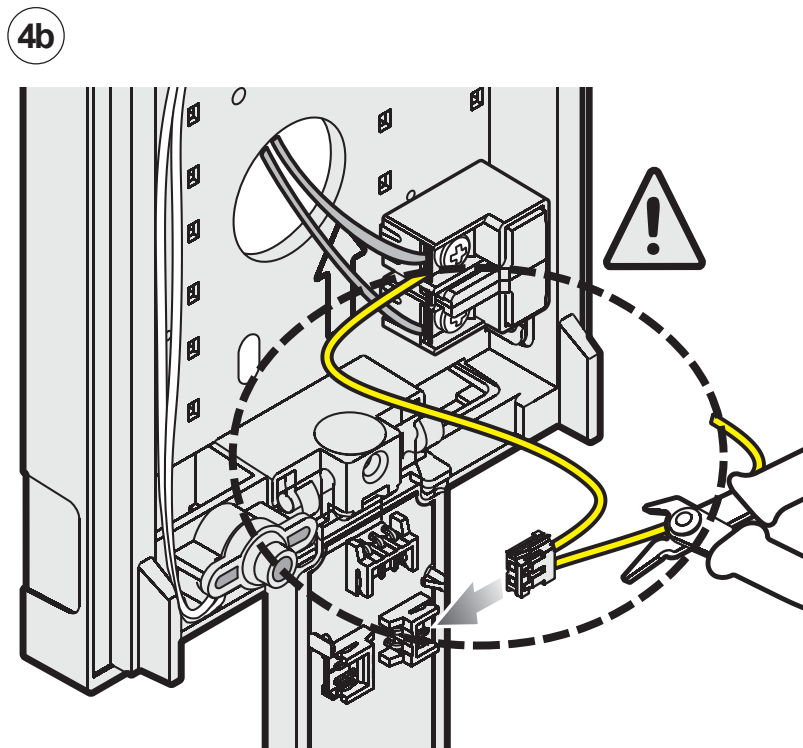
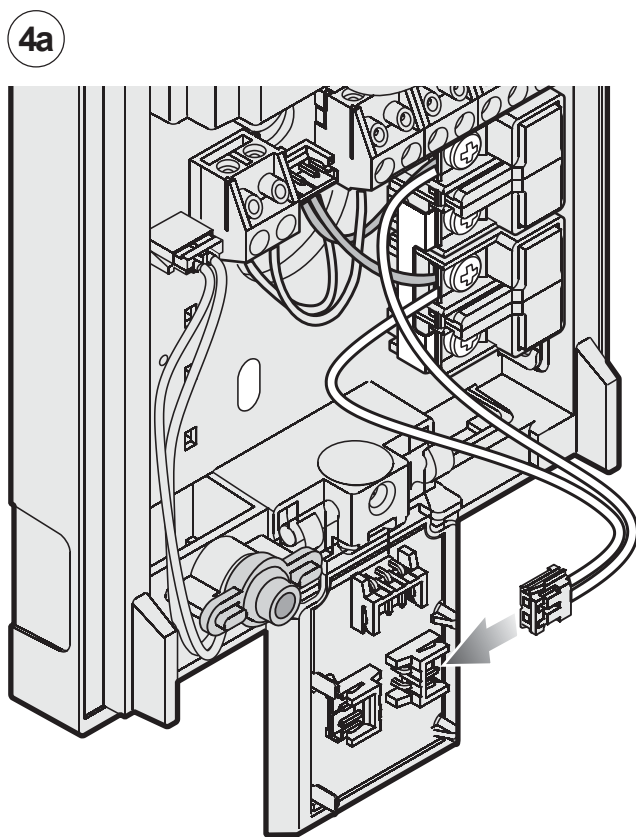
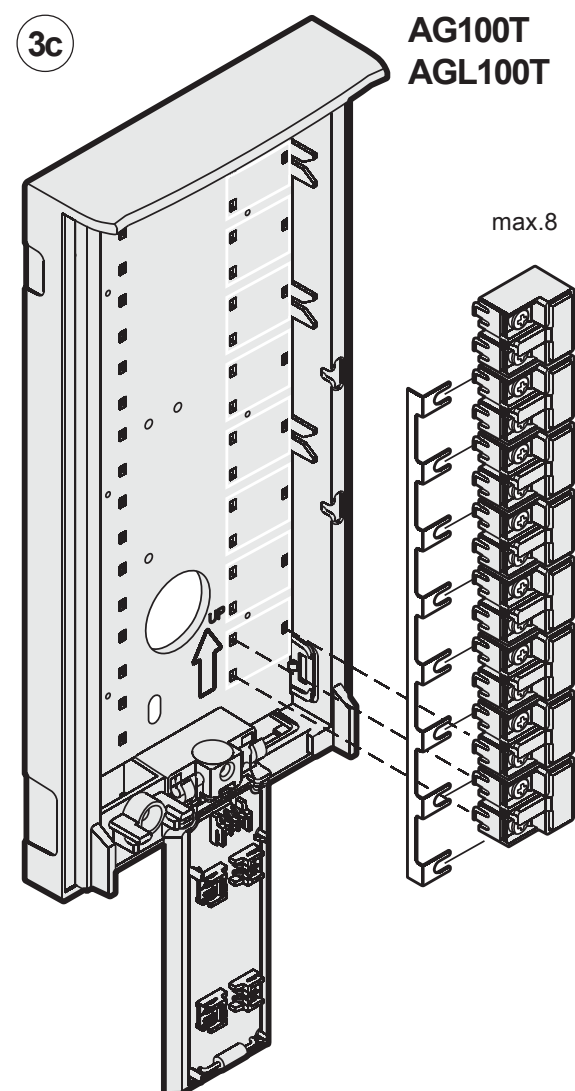
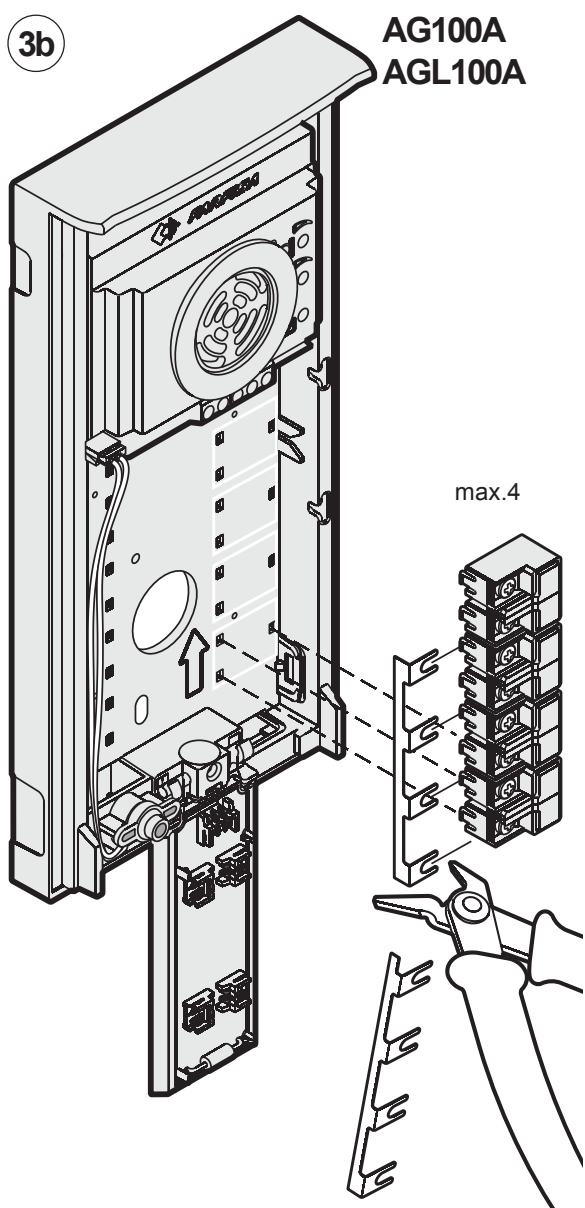
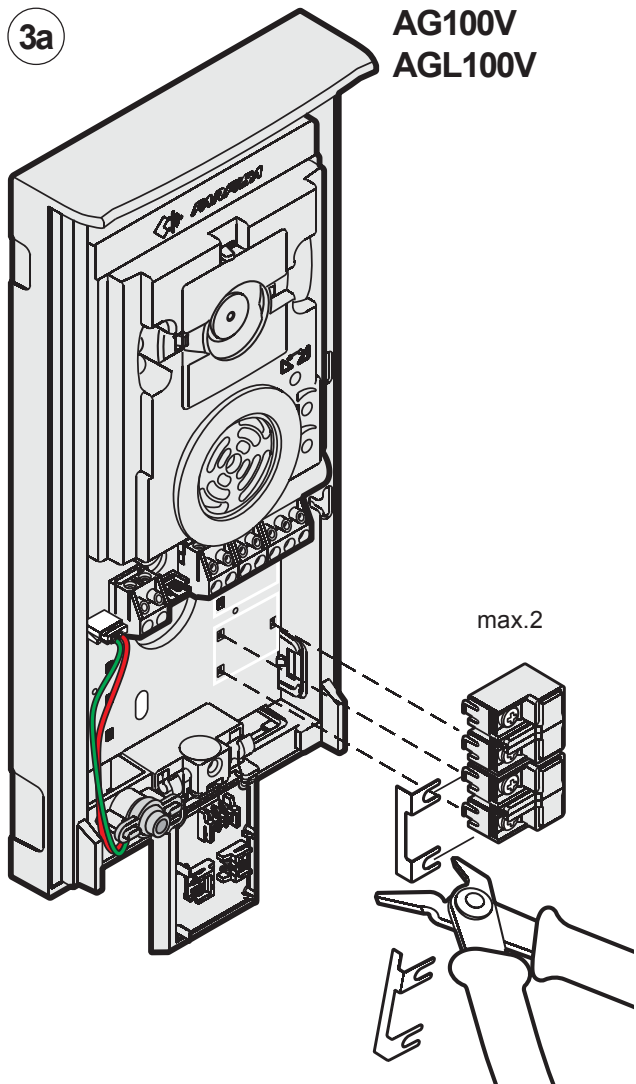

Tagliare od isolare il conduttore non utilizzato.

Cut and keep insulated not used wire.

Couper ou isoler le conducteur inutilisé.

Cortar o aislar el conductor no utilizado.

Cortar ou isolar o condutor não utilizado.

Nicht verwendeten Leiter abschneiden oder isolieren.

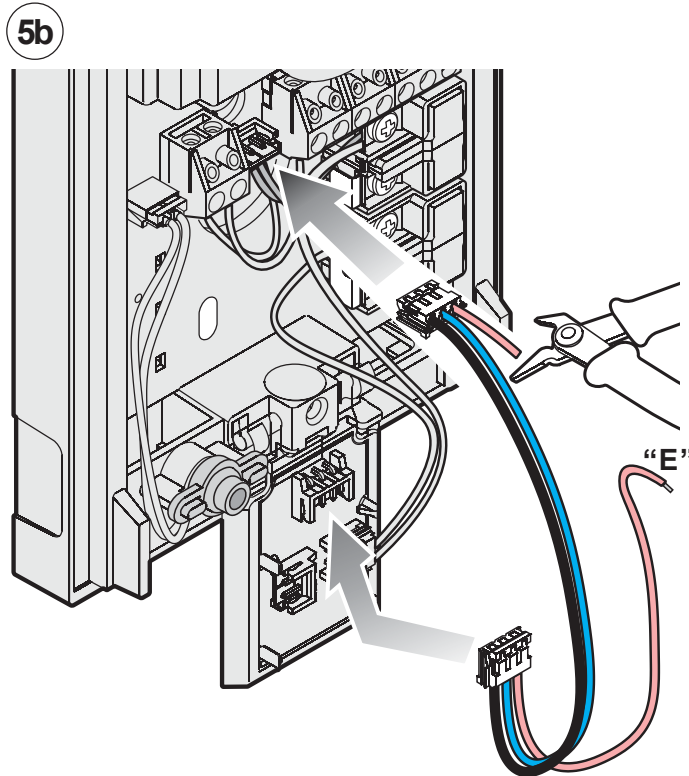
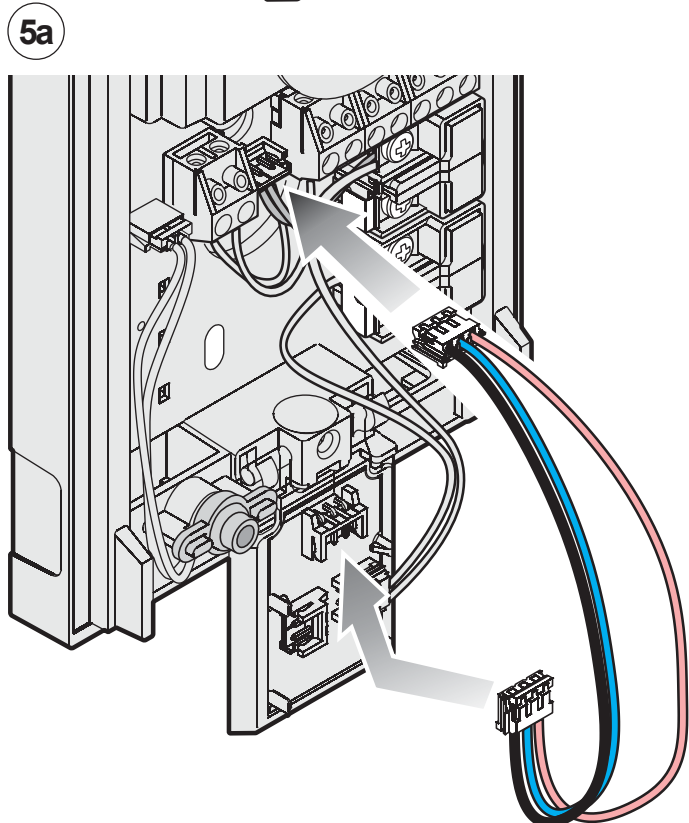

Terminale "E".

Tagliare il conduttore rosso per creare il terminale "E" solamente se richiesto dallo schema installativo.

"E" terminal.

Cut the red wire to get "E" terminal only if required by the installation diagram.

Borne "E".

Couper le conducteur rouge pour créer la borne "E" uniquement si préconisé par le schéma d'installation.

Terminal "E".

Cortar el conductor rojo para crear el terminal "E" solamente si demandado por el esquema de instalación.

Terminal "E".

Cortar o condutor vermelho para criar o terminal "E" somente se for solicitado pelo esquema de instalação.

Steckverbinder „E“.

Roten Leiter zur Herstellung des Steckverbinders „E“ nur dann abschneiden, wenn dies laut Schaltplan ausdrücklich notwendig ist.

SEQUENZA MONTAGGIO MODULI
ASSEMBLY MODULE SEQUENCE
SÉQUENCE DE MONTAGE DES MODULES
SECUENCIA MONTAJE MÓDULOS
SEQUÊNCIA DE MONTAGEM DE MÓDULOS
REIHENFOLGE BEI DER MODULMONTAGE

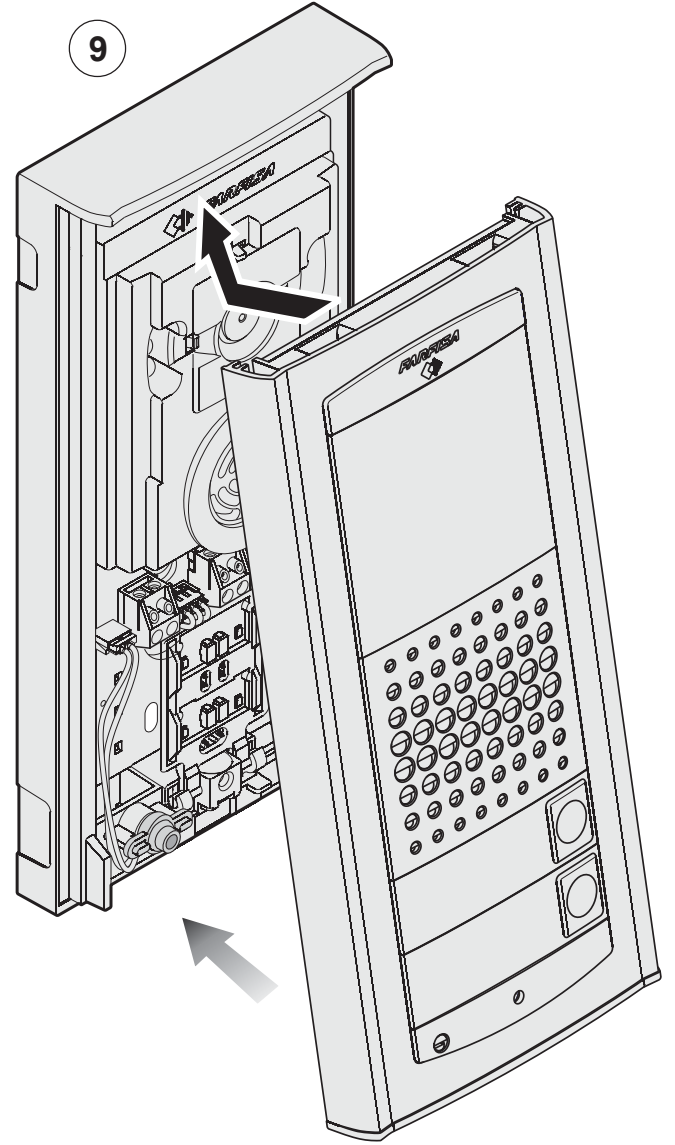
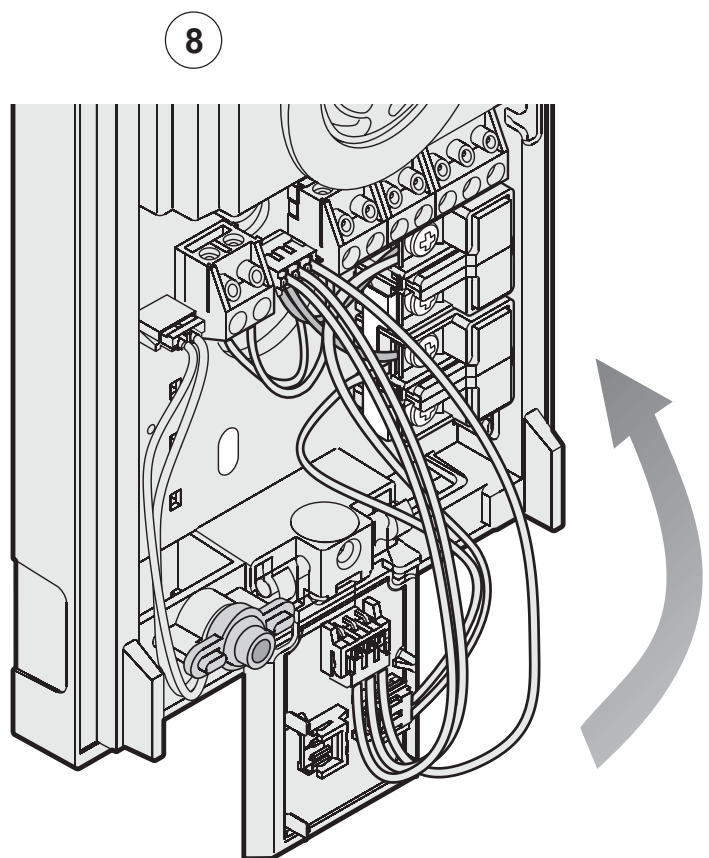
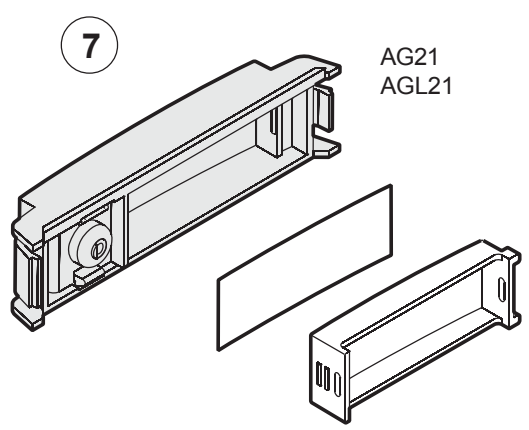
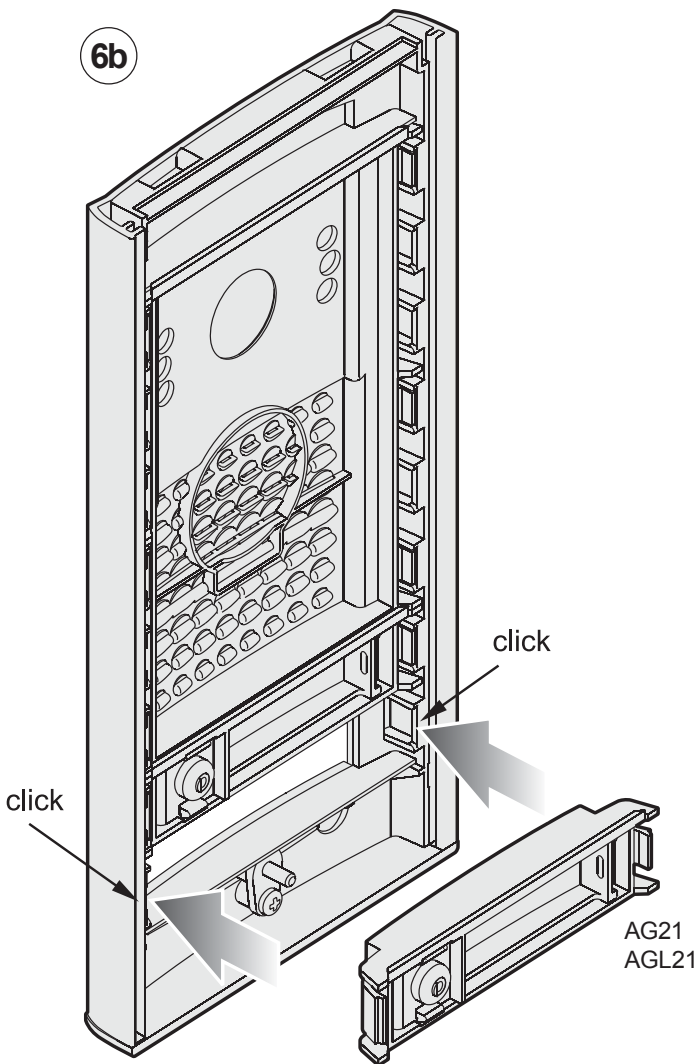
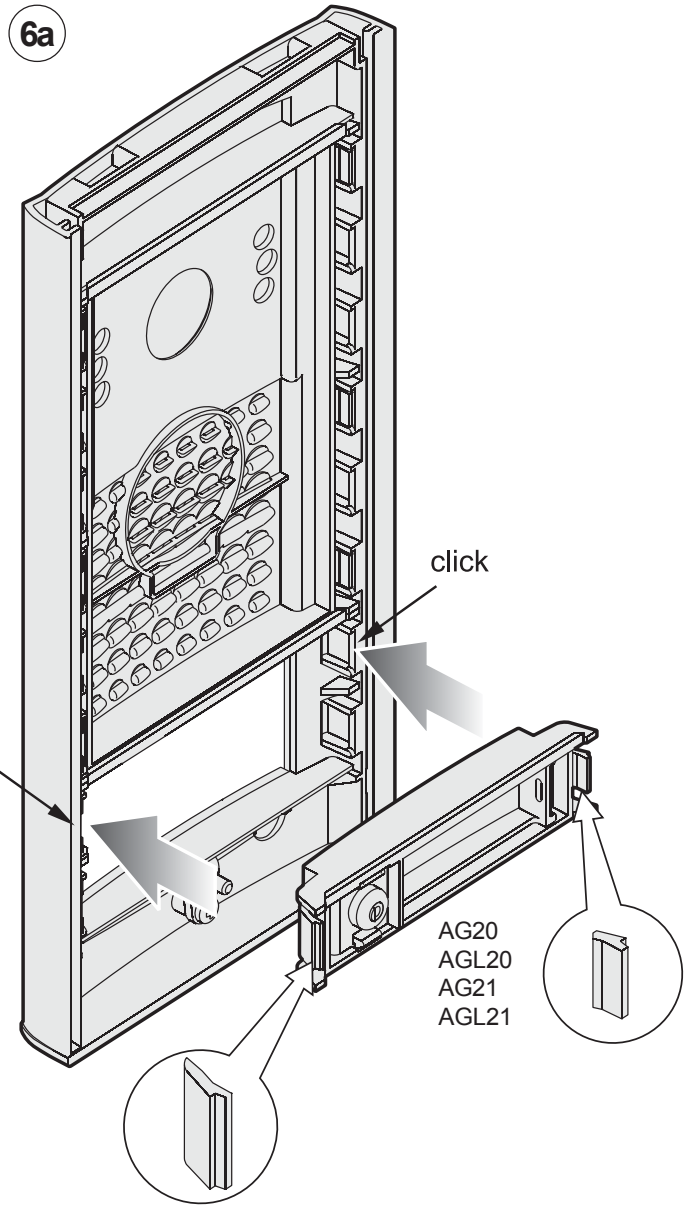
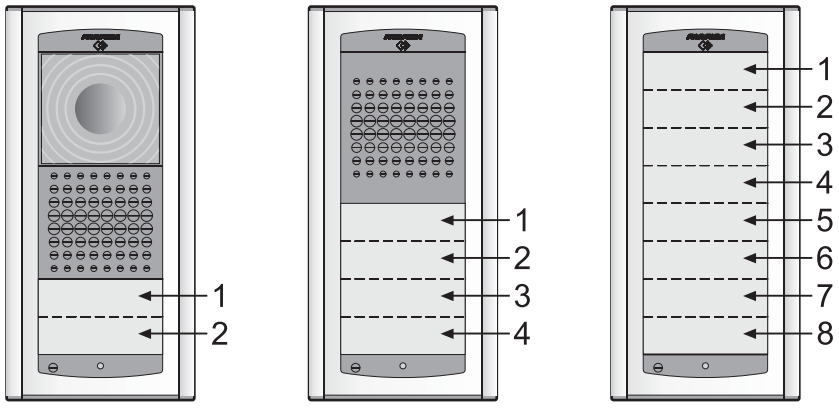

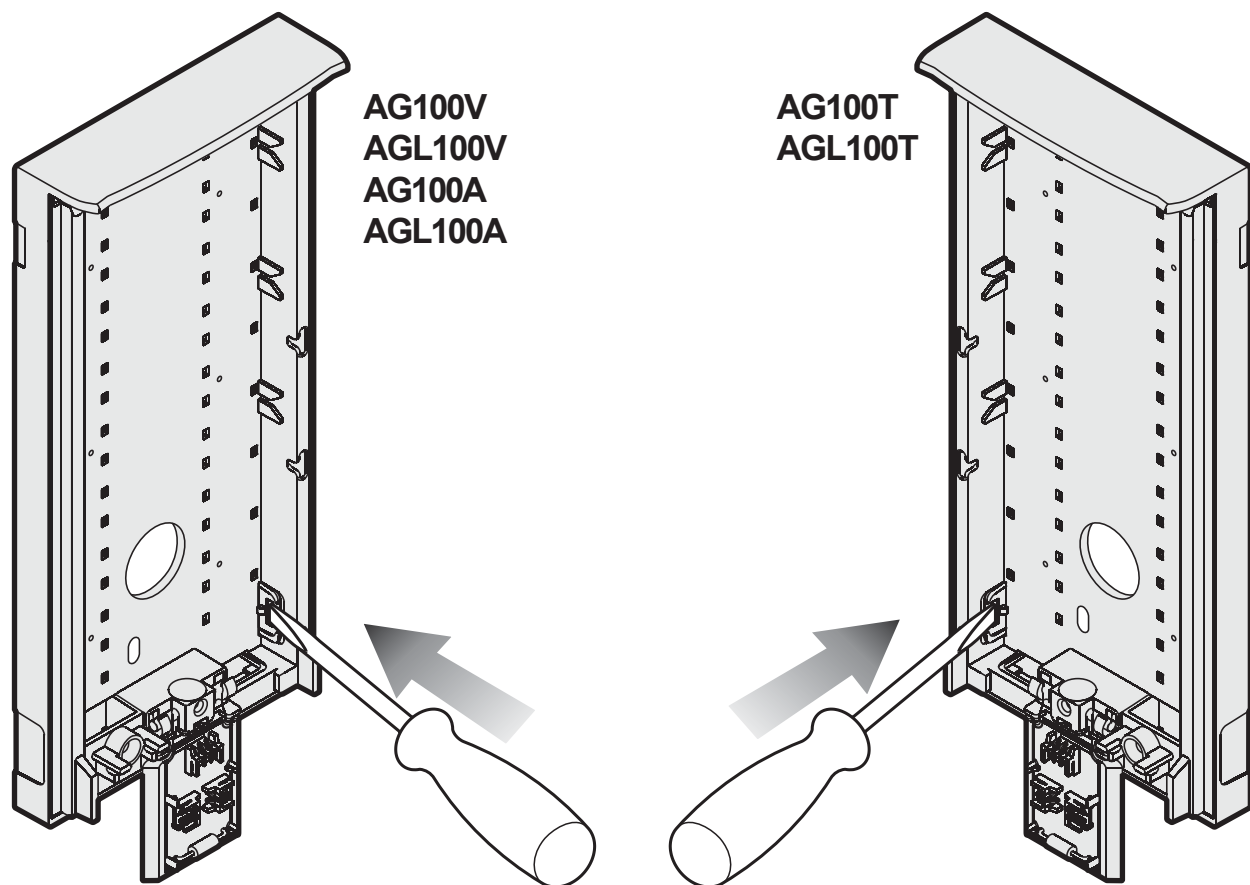

AG100V
AGL100V
AG100A
AGL100A

AG100T
AGL100T

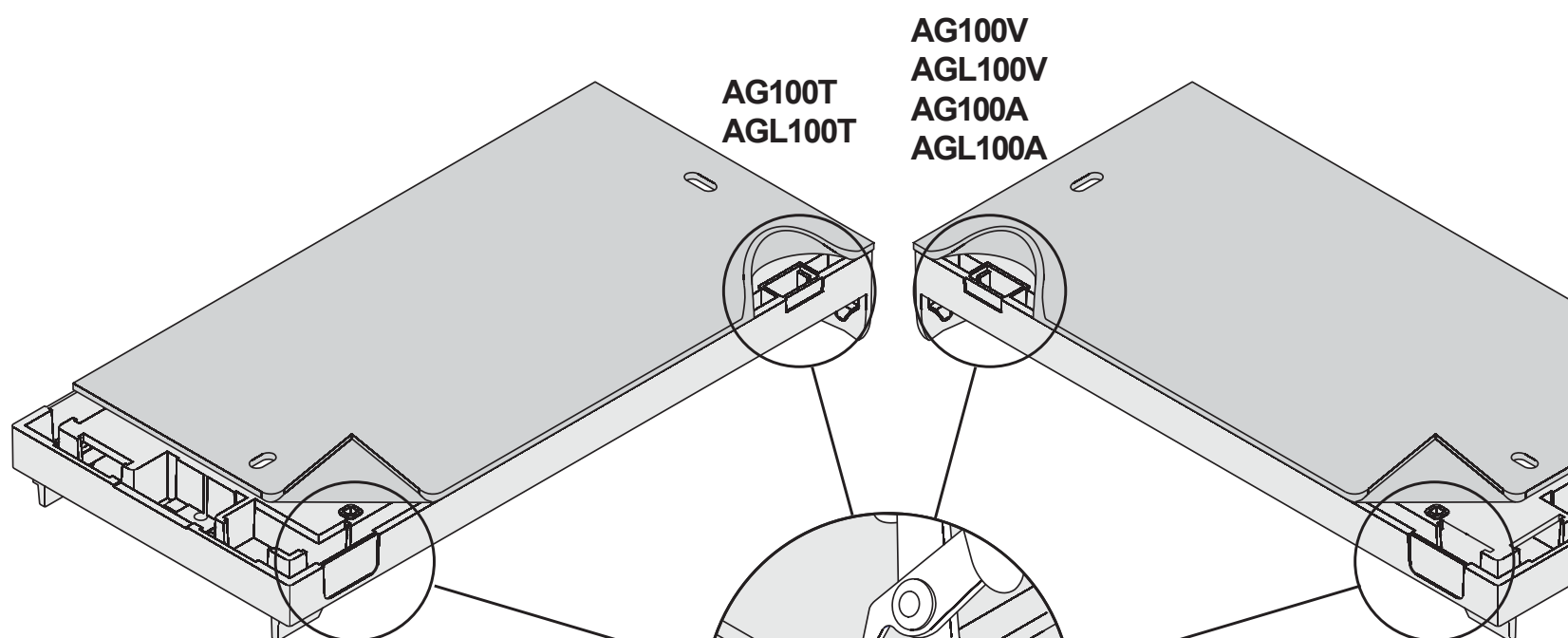
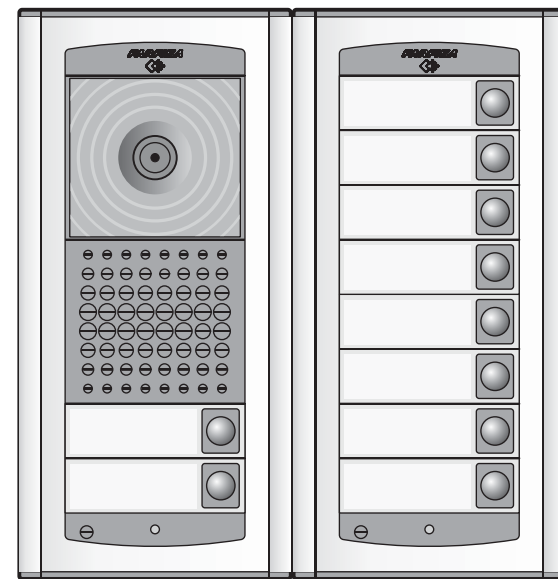

AG100T
AGL100T

AG100V
AGL100V
AG100A
AGL100A

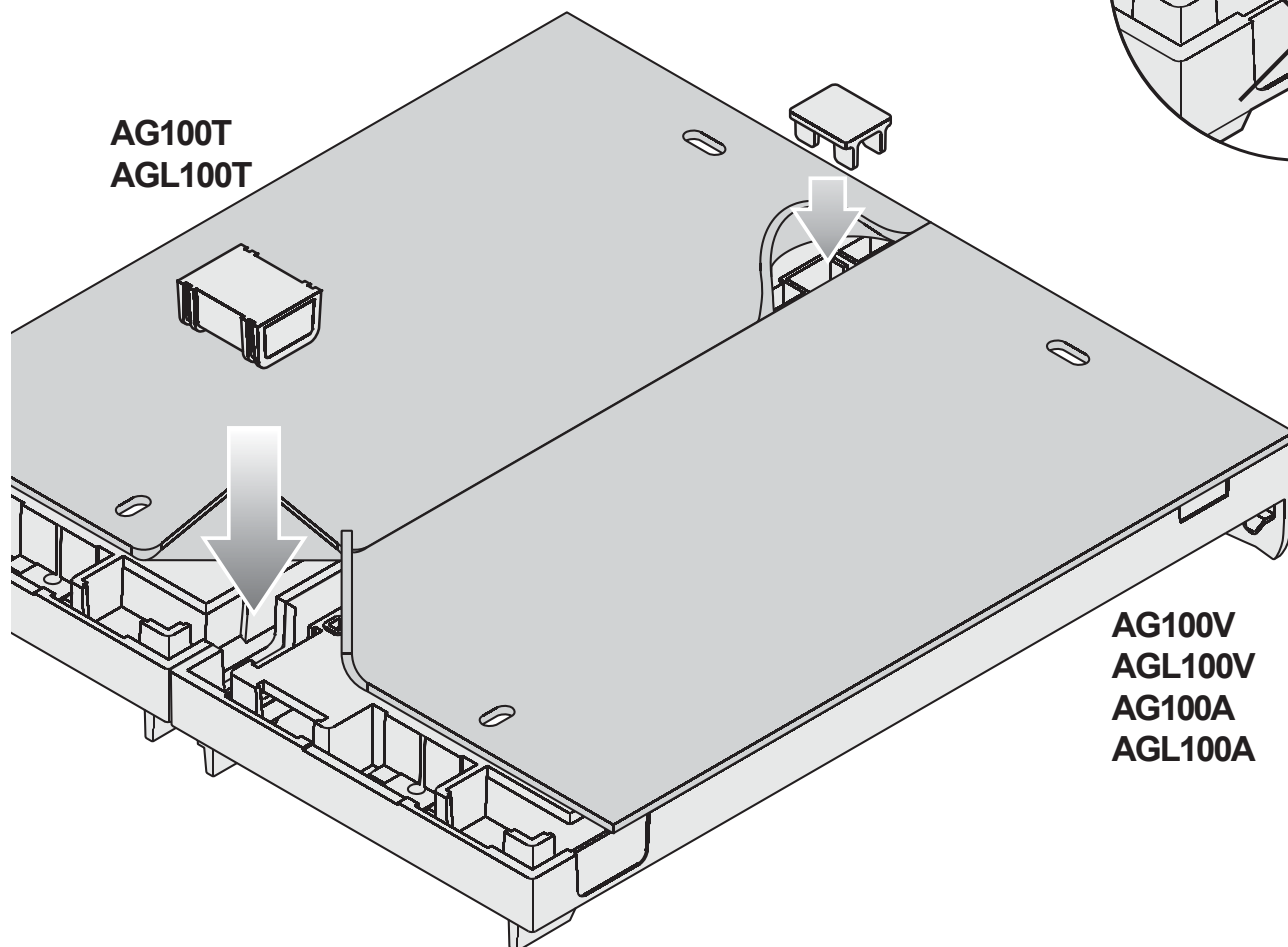

AG100T
AGL100T

AG100V
AGL100V
AG100A
AGL100A



Smaltire il dispositivo secondo quanto prescritto dalle norme per la tutela dell'ambiente.
Dispose of the device in accordance with environmental regulations.
 Écouler le dispositif selon tout ce qu'a été prescrit par les règles pour la tutelle du milieu.
 Eliminar el aparato según cuánto prescrito por las normas por la tutela del entorno.
 Disponha do dispositivo conforme regulamentos ambientais.
 Das Gerät muß gemäß den geltenden Umweltregelungen entsorgt werden.

Cod. M527044700

ACI srl Farfisa Intercoms
 Via E. Vanoni, 3 • 60027 Osimo (AN) • Italy
 Tel: +39 071 7202038 (r.a.) • Fax: +39 071 7202037
 e-mail: info@farfisa.com • www.farfisa.com